



INSTALLATION INSTRUCTIONS TO REPLACE AN OBSOLETE HONEYWELL GTA (GAS TRAIN ASSEMBLY) WITH A PROFLAME GTA IN A SPECTRA™ LSS SERIES GAS FIREPLACE



! WARNING

THIS KIT IS TO BE INSTALLED BY A QUALIFIED SERVICE TECHNICIAN OR OTHER QUALIFIED AGENCY IN ACCORDANCE WITH THE MANUFACTURER'S INSTRUCTIONS AND ALL CODES AND REQUIREMENTS OF THE AUTHORITY HAVING JURISDICTION IN THE USA OR CANADA. IF THESE INSTRUCTIONS ARE NOT FOLLOWED EXACTLY, A FIRE OR EXPLOSION MAY RESULT, CAUSING PROPERTY DAMAGE, PERSONAL INJURY OR LOSS OF LIFE. THE QUALIFIED AGENCY PERFORMING THIS WORK ASSUMES RESPONSIBILITY FOR THIS INSTALLATION.

KITS

- H8093 GTA Replacement/Conversion Kit — 35N Spectra
- H8094 GTA Replacement/Conversion Kit — 35P Spectra
- H8095 GTA Replacement/Conversion Kit — 40N Spectra
- H8096 GTA Replacement/Conversion Kit — 40P Spectra

KIT CONTENTS

- 1 ea. Gas Train Assembly
- 1 ea. GTMS Wire Harness (2 ft.)
- 1 ea. Fan Control Module Kit
- 1 ea. Transmitter (Remote Control) Kit
- 1 ea. Velcro Tape (12-inch roll)
- 1 ea. Direct Vent Spectra Series Care & Operation Instructions (875,020M)
- 1 ea. Rocker Switch
- 1 ea. DFC (Direct Fireplace Control) Wire Harness
- 1 ea. Receiver Kit
- 1 ea. Switch Bracket
- 1 ea. Proflame DFC Board
- 1 ea. Electrical Cord

TOOLS NEEDED

- Safety Glasses
- Scissors or Knife (to cut Velcro tape)
- 5/16-inch Nut Driver, Socket, or Wrench

GENERAL INFORMATION

This kit is offered as a replacement for the obsolete Honeywell Gas Train Assembly (GTA) in Lennox™ Spectra™ LSS Series gas fireplaces.

The SIT Proflame GTA in this kit adds the following upgraded features of the Lennox Total Comfort Control™ system to older Spectra fireplaces:

- ▶ Full-function remote control of flame height and blower speed.
- ▶ Intelligent temperature control.
- ▶ Standing and intermittent pilot modes.
- ▶ Battery back-up valve system for operation during a power failure.

TURN OFF THE GAS SUPPLY TO THE APPLIANCE, and disconnect power supply at the circuit breaker. Ensure appliance is cold.

CAUTION: THE GAS SUPPLY SHALL BE SHUT OFF PRIOR TO DISCONNECTING THE ELECTRICAL POWER, BEFORE PROCEEDING WITH THE CONVERSION.

INSTALLATION INSTRUCTIONS

READ ALL THE STEPS BEFORE STARTING THE CONVERSION.

INSTALLER NOTICE: THESE INSTRUCTIONS (AND THE PROVIDED CARE & OPERATION INSTRUCTIONS) MUST BE LEFT WITH THE APPLIANCE.

ALL WARNINGS, PRECAUTIONS AND INSTRUCTIONS IN THE INSTALLATION INSTRUCTIONS AND CARE AND OPERATION MANUALS PROVIDED WITH THE APPLIANCE APPLY TO THESE INSTRUCTIONS.

IF YOU ENCOUNTER ANY PROBLEMS, NEED CLARIFICATION OF THESE INSTRUCTIONS OR ARE NOT QUALIFIED TO PROPERLY INSTALL THIS KIT, CONTACT YOUR LOCAL DISTRIBUTOR OR DEALER.

- Step 1. Remove the log grate.
- Step 2. Remove the two (2) screws attaching the front burner; then remove the front burner.
- Step 3. Remove the four (4) refractory panels in the following order:
 - 3.1. Remove the two sides.
 - 3.2. Remove the back.
 - 3.3. Remove the floor.
- Step 4. Remove the four (4) screws attaching the top burner assembly; then remove the top burner.
- Step 5. Remove the ten (10) screws attaching the existing Honeywell gas train assembly (GTA); then remove the GTA.
- Step 6. Remove the remaining Honeywell components from the lower control compartment.
- Step 7. Install the new Proflame GTA components in the following order (refer to **Figures 1, 2, and 3**, below and on the reverse):
 - 7.1. Attach the new Proflame DFC Board to the fireplace floor using strips of Velcro tape cut to size.

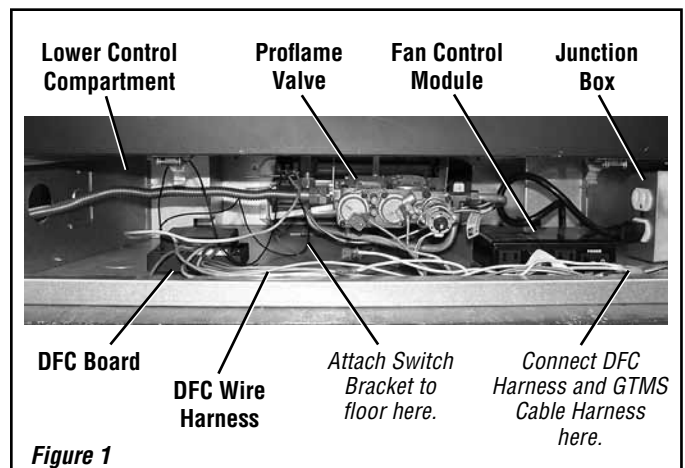

Figure 1

- 7.2. Attach the Fan Control Module to the fireplace floor using strips of Velcro tape cut to size.
- 7.3. Connect the Fan Control Module power cord to the lower outlet of the two duplex plugs at the appliance Junction Box.
- 7.4. Attach the Switch Bracket to the fireplace floor using strips of Velcro tape cut to size.

Note: If possible, it is preferred that the Switch Bracket be screwed to the fireplace floor using self-tapping screws (not provided). Access for installing the screws can be had through the opening left by the removed GTA.
- 7.5. Install the Rocker Switch in the Switch Bracket.
- 7.6. Attach the large connector of the DFC Wire Harness to the DFC Board.
- 7.7. Attach the two (2) single white connectors to the Rocker Switch, and then connect the pink, green, and double-white wires, using their individual connectors, to the matching wires of the GMTS Cable Harness assembly.
- 7.8. Connect the black, white, and green wires of the Fan to the black, white, and green wires of the provided Electrical Cord.
- 7.9. Plug the Electrical Cord into the Fan Control Module.
- 7.10. Install the new Proflame Gas Train Assembly (in place of the removed GTA), using the ten (10) existing screws.
- 7.11. The GTA has three (3) wires attached to it — a yellow ground wire, a black-tipped sparker wire, and a black-tipped sensor wire. Attach the wires to the positions indicated on the DFC Board.

- 7.12. Connect the yellow, green, and orange braided wires of the DFC Wire Harness to the valve — the yellow to the ground spade on the bottom left side of the valve, and the orange and green wires to their respective valve spades.
 - 7.13. Attach the red/purple/gray connector of the Receiver's umbilical harness to the Fan Control Module's com port (channel side up).
 - 7.14. Connect the earth-toned connector to the valve.
 - 7.15. Route the Receiver's umbilical cord to a convenient location on the wall for the Receiver Kit.
- Step 8. To complete the procedure, follow the instructions in **Steps 1 through 4 in reverse order** to reinstall the remaining components.

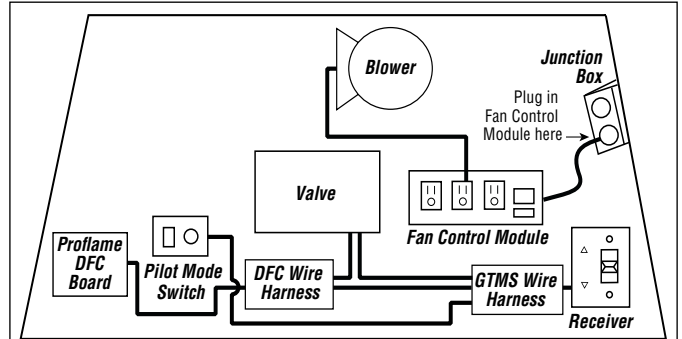

Figure 2: Spectra™ Proflame component placement diagram

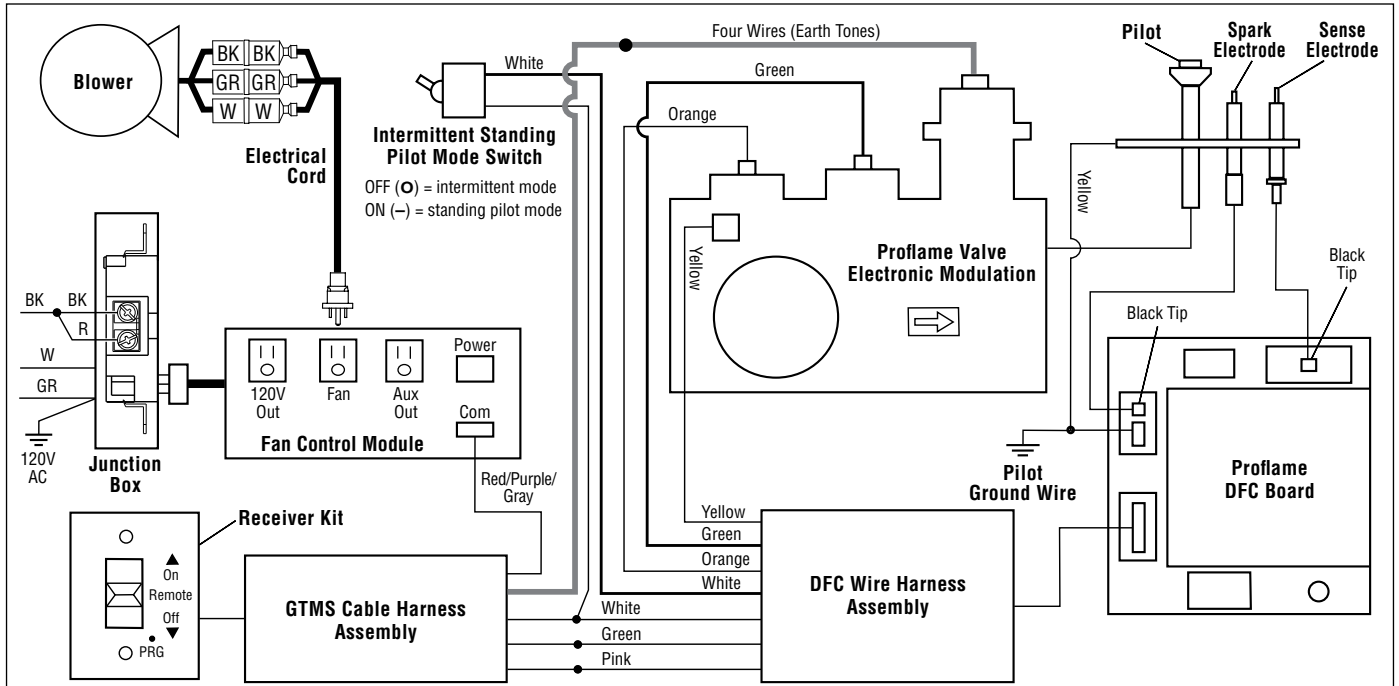

Figure 3: Spectra™ Proflame wiring diagram

NOTE: DIAGRAMS & ILLUSTRATIONS ARE NOT TO SCALE.

Lennox Hearth Products reserves the right to make changes at any time, without notice, in design, materials, specifications, prices and also to discontinue colors, styles and products. Consult your local distributor for fireplace code information. Lennox, Spectra, Dave Lennox Signature Collection, Lennox Total Comfort Control, and all related logos are trademarks of Lennox Hearth Products.

